

Improved RSVP

- 1 Lockout feature** integrated into handle adaptor, which accommodates customer's lockout device in open and closed positions.
- 2 Mechanical precision stop** for open position with locking set screws for adjustment. Actuator torque is transmitted directly through the stem adaptor to the stop. Stop ensures correct ball orientation and prevents misalignment on automated valve.
- 3 Integral mounting flange** prevents disassembly. Integral flange provides rigid mounting of actuation with no loosening or shifting between bracket and body.
- 4 Double-keyed stem** for reliable and more convenient adaptation of gears, pneumatics, hydraulics and motor operators.

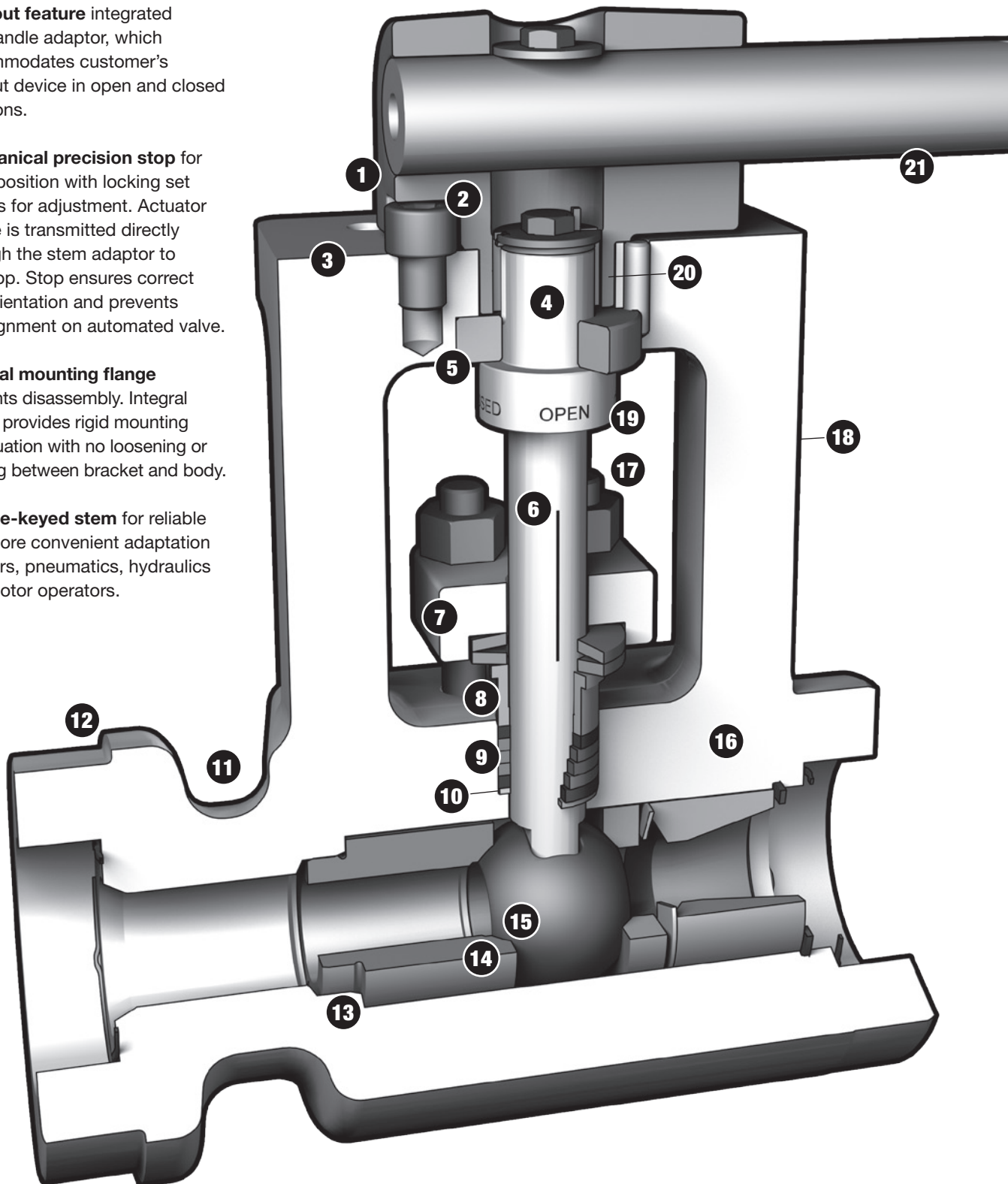

Operating convenience...Sealing performance...Dependability.



- 5 Stem bushing** prevents stem blowout and aligns stem radially. **Coated** for wear resistance.
- 6 Single scribe line** on gland aligns with open or closed scribe line on stem to indicate proper ball and seat alignment and correct ball direction.
- 7 Two-piece gland** with concentric live loading has ample allowance for adjustments while maintaining sealing integrity. The gland flange, thruster studs and nuts are 316SS for corrosion resistance, while the thruster is coated for wear resistance. The live load springs are Inconel.
- 8 The gland thruster** is machined for a continuous tight connection with the stem and packing box to prevent packing extrusion and maintain stem alignment in operation.
- 9 Deep stuffing box** with proven .125 inch cross-section Chesteron™ packing and dual anti-extrusion rings that provide reliable sealing and longevity.
- 10 Metal anti-extrusion ring** minimizes packing extrusion.
- 11 Integral vented body design** protects the valve during Post Weld Heat Treatment (PWHT).
- 12 Stop** on downstream end indicates limit for heat ribbons used for stress relief. **Raised diameter** acts as radiant fin for heat dissipation during Post Weld Heat Treatment (PWHT.)
- 13 Proven press-fit seat design.** ASME 1500 Limited Class, 410SS / Chromium Carbide ASME 3100 / 4500 Limited Class, Inconel 718 / Chromium Carbide
- 14 Oversized bore** at seat face allows for rapid thermal expansion without exposing seat face to process flow. **Wider seat faces** increase seal longevity.
- 15 Mate-lapped ball and seat** of same material and coating to match thermal expansion rates.
- 16 Forged body** for reliable pressure containment.
- 17 Increased clearance** and visibility around packing nuts provides easier access for adjustment. Gland components can be raised for installation of skive-cut packing rings. **Greater length** between stem bushing and packing box bearing surfaces for more precise stem alignment.
- 18 Nameplate** permanently attached to mounting flange leg, visible above insulation. Nameplate location indicates high-pressure end in the closed position.
- 19 Stem with integrated thrust bearing** prevents disassembly in-line and supports greater axial load. Reliable wear life. **Coated** stem for wear and gall resistance. Marked with open and close to clearly show operating position. Stem does not extend above the face of the mounting flange.
- 20 Adaptor is supported** in the bore of the mounting flange for the length engaged with the stem. This is provided by MOGAS.
- 21 Handle can be repositioned** to any location along its length. Can be applied as a T-handle or reversed to downstream for limited clearance. Handle length is 24 inch maximum in standard pipe outside diameters.

Features Not Shown

Flow arrow forged into mounting flange visible above insulation.

Complies with **ASME B16.34** requirements.

Socketweld ends per **ASME B16.11.**

Blank configuration for butt weld and customer end connections.

Actuator mounting per **MSS SP-101.**

Metallurgically bonded coating as standard on ASME 3100 and 4500 Class valves. Optional on ASME 1500 Class valves.

Patented design.