

Applications

- Boiler drains
- Feedwater drains
- Steam drum vents
- Isolation valve for bypass lines
- Economizer header drains

End Connections

- Socketweld
- Buttweld
- Flanged¹

Sizes

3/4 to 2-1/2 inch

¹ Available Upon Request

Features

Ball and Seats

- Mate-lapped for 100% contact
- Ensures absolute shutoff
- Corrosion resistant
- Seats are protected from flow in open / closed position
- Inconel 718 CC upgrade available to provide additional resistance to corrosion¹

Mechanical Precision Stop

- Prevents turning ball 180°
- Eliminates misalignment

Stem & Packing Arrangement

- Live Loading
- Quarter-turn non-rising stem does not deteriorate packing
- Extensive stuffing box
- Dual anti-extrusion rings keep packing in place

Rigid Mounting Bracket

- Designed to support actuator in any position

Seat Spring

- Assisted by line pressure, provides a constant mechanical force on ball against seat to maintain seal

Bill of Materials

Item No.	Description	Material
1	Ball	410SS / CC Coated or Inconel 718 / CC Coated
2	Seat	410SS / CC Coated or Inconel 718 / CC Coated
3	Spring	Inconel 718
4	Body	A182 F22 A105 A182 F91
5	Stem	A276 GR431 Nitrided
6	Live Loading	Inconel 718
7	Gland Thruster	316 Nitrided
8	Gland Flange	410SS
9	Stem Packing	Expanded Graphite
10	Anti-Extrusion Rings	Braided Graphite w/ Inconel Wires
11	Metal Anti-Extrusion Ring	316SS
12	Retaining Ring	A638 660

- Standard four-year warranty; one-year warranty on high-cycle applications (1 cycle per day, 365 days per year)
- Patented design

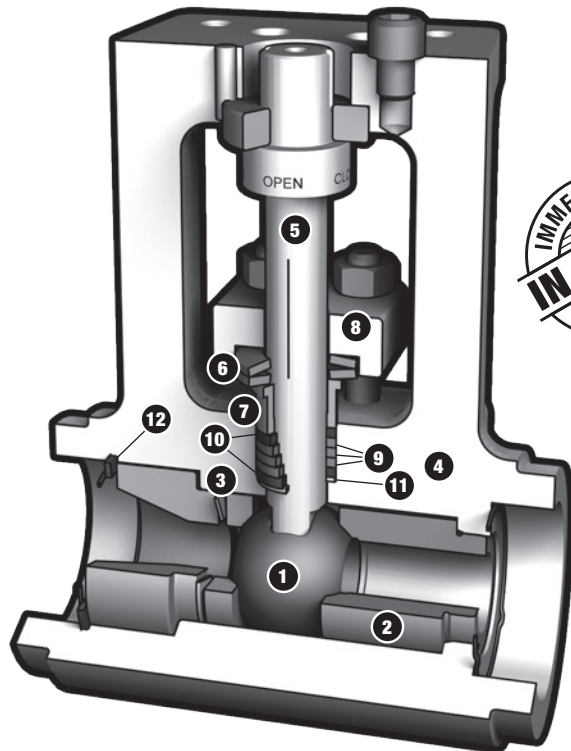

Dimensions² (in)

Model	Bore	SW End	A	B	C	D	E	Weight
RSVP-UC	0.63	3/4	3.73	6.25	9.79	5.03	6.50	15 lb
		1, 1-1/2	2.50	5.00	9.79	5.03	6.50	15 lb
RSVP-UF	1.00	1-1/2, 2	3.19	6.38	21.56	6.63	8.80	32 lb
RSVP-UL	1.30	2	3.51	7.5	22.38	7.63	10.12	54 lb
		2-1/2	3.75	7.5	22.38	7.63	10.12	53 lb
RSVP-UM ³	1.50	2	5.59	9.59	—	7.63	—	61 lb
		2-1/2	3.88	7.75	—	7.63	—	58 lb

Dimensions² (mm)

Model	Bore	SW (DN)	A	B	C	D	E	Weight
RSVP-UC	16	20	95	159	249	128	165	7 Kg
		25, 40	63.5	127	249	128	165	7 Kg
RSVP-UF	25	40, 50	81	162	548	168	224	15 Kg
RSVP-UL	33	50	89	191	568	194	257	24 Kg
		65	95	191	568	194	257	24 Kg
RSVP-UM ³	38	50	142	244	—	194	—	28 Kg
		65	99	197	—	194	—	26 Kg

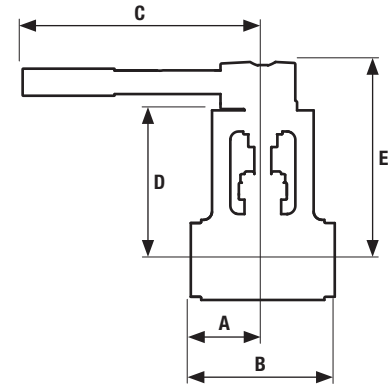

² Consult factory for F91 dimensions.

³ RSVP-UM is designed to meet ASME TDP-1 1998 full-bore and reliability requirements, and is a non-standard stock item.

Temperature vs Pressure — Limited Class Ratings

Class	Mat'l.	Temperature (°F)																		
		-20 to 100	200	300	400	500	600	650	700	750	800	850	900	950	1000	1050	1100			
ASME 600 Maximum Pressure (psig)	F22 ⁴	1500	1500	1480	1455	1450	1440	1430	1415	1415	1415	1355	1200	953	688	446	282			
	A105 ⁵	1500	1500	1480	1465	1465	1465	1430	1380	1270	1030	—	—	—	—	—	—			
	F91	1500	1500	1500	1500	1500	1500	1500	1465	1460	1440	1355	1200	953	862	862	775			
ASME 900 Maximum Pressure (psig)	F22 ⁴	2250	2250	2220	2185	2175	2165	2145	2120	2120	2120	2030	1800	1433	1045	681	426			
	A105 ⁵	2250	2250	2220	2200	2200	2200	2145	2075	1905	1545	—	—	—	—	—	—			
	F91	2250	2250	2250	2250	2250	2250	2250	2200	2185	2160	2030	1800	1433	1311	1311	1175			
ASME 1500 Maximum Pressure (psig)	F22 ⁴	3750	3750	3695	3640	3620	3605	3580	3535	3535	3535	3385	3000	2412	1785	1170	732			
	A105 ⁵	3750	3750	3700	3665	3665	3665	3575	3455	3170	2570	—	—	—	—	—	—			
	F91	3750	3750	3750	3750	3750	3750	3750	3665	3645	3600	3385	3000	2412	2250	2250	2015			
Class	Mat'l.	Temperature (°C)																		
		-29 to 38	50	100	150	200	250	300	325	350	375	400	425	450	475	500	538	550	575	600
ASME 600 Maximum Pressure (barg)	F22 ⁴	103	103	103	102	100	100	100	99	98	98	98	98	94	86	72	47	40	27	18
	A105 ⁵	103	103	103	102	101	101	101	100	98	94	87	72	—	—	—	—	—	—	
	F91	103	103	103	103	103	103	103	103	103	101	101	99	95	86	72	59	59	59	50
ASME 900 Maximum Pressure (barg)	F22 ⁴	155	155	155	153	151	150	149	149	148	146	146	146	141	128	109	72	61	41	27
	A105 ⁵	155	155	155	153	152	152	152	150	147	141	130	108	—	—	—	—	—	—	
	F91	155	155	155	155	155	155	155	155	154	152	151	149	143	128	109	90	90	89	76
ASME 1500 Maximum Pressure (barg)	F22 ⁴	259	259	258	255	251	250	249	248	246	244	244	244	236	214	183	123	104	70	46
	A105 ⁵	259	259	259	255	253	253	253	251	245	236	217	180	—	—	—	—	—	—	
	F91	259	259	259	259	259	259	259	259	257	253	251	248	241	214	183	155	155	153	130

⁴ F22 not recommended for prolonged use above 1100°F / 593°C per ASME B16.34.

⁵ A105 not recommended for prolonged use above 800°F / 427°C per ASME B16.34.

Cv

Bore (inches)	Pipe Size (inches) / Schedule									
	3/4 Sch 160	3/4 Sch XXS	1 Sch 160	1 Sch XXS	1-1/2 Sch 160	1-1/2 Sch XXS	2 Sch 160	2 Sch XXS	2-1/2 Sch 160	2-1/2 Sch XXS
0.63	40	19	18	38	11	13	—	—	—	—
1.00	—	—	—	—	43	70	33	37	—	—
1.30	—	—	—	—	—	—	90	117	66	82