

ASME 4500 Limited Class

Applications

Boiler drains
 Turbine drains
 Above and below seat drains
 Feedwater drains
 Steam drum vents
 Superheater vents and drains
 Sootblower isolation
 Isolation valve for bypass lines
 Economizer header drains

End Connections

Socketweld
 Buttweld
 Flanged¹

Sizes

3/4 to 2-1/2 inch

¹ Available Upon Request

Features

Inconel 718 Ball and Seats

- Mate-lapped for 100% contact
- Ensures absolute shutoff
- Corrosion resistant
- Seats are protected from flow in open / closed position

Chromium Carbide Coating

Advantages

- Withstands thermal shock
- Handles high cycling applications
- High strain to fracture
- Maintains strength of base metal
- Erosion resistant

Rigid Mounting Bracket

- Designed to support actuator in any position

Stem & Packing Arrangement

- Live loading
- Quarter-turn non-rising stem does not deteriorate packing
- Extensive stuffing box
- Dual anti-extrusion rings keep packing in place

Mechanical Precision Stop

- Prevents turning ball 180°
- Eliminates misalignment

Seat Spring

- Assisted by line pressure, provides a constant mechanical force on ball against seat to maintain seal

Bill of Materials

Item No.	Description	Material
1	Ball	Inconel 718 / CC Coated
2	Seat	Inconel 718 / CC Coated
3	Spring	Inconel 718
4	Body	A182 F22 A182 F91
5	Stem	A276 GR 431 Nitrided
6	Stem Bushing	431SS / Melonite and Xylan Coated
7	Gland Thruster	431SS Melonite and Xylan Coated
8	Gland Flange	410SS
9	Stem Packing	Expanded Graphite
10	Anti-Extrusion Rings	Braided Graphite w/ Inconel Wires
11	Metal Anti-Extrusion Ring	316SS
12	Pusher Seat	431SS / Nitrided
13	Live Loading	Inconel 718

- Integral vented body design allows installation per ASME B31.1 PWHM requirements
- Standard four-year warranty; one-year warranty on high-cycle applications (1 cycle per day, 365 days per year)
- Patented design

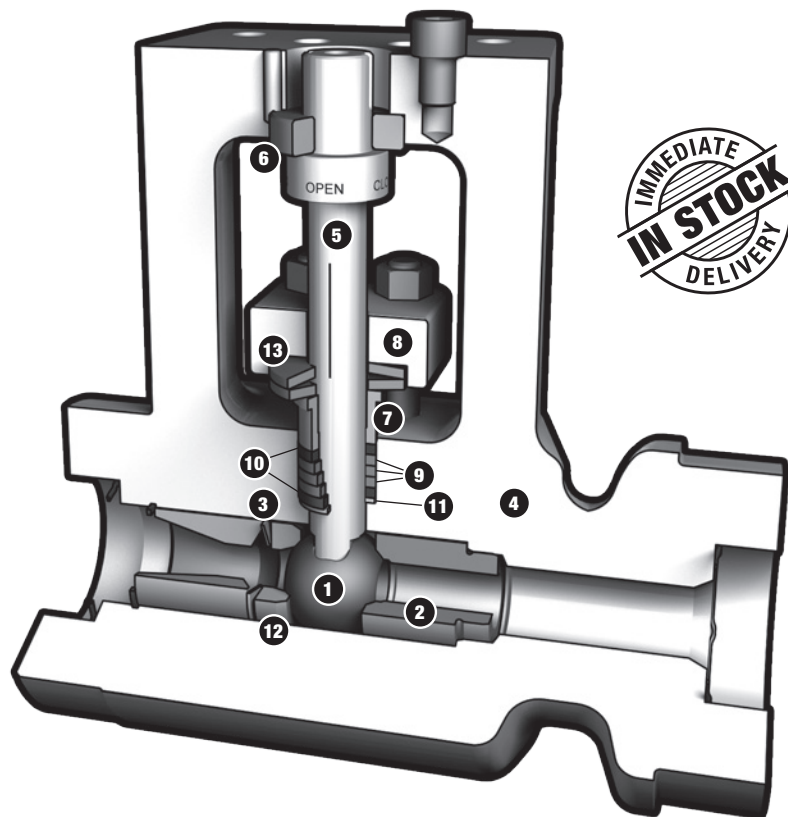

Engineered for Extreme Conditions

Dimensions (in)

Model	Bore	SW End	A	B	C	D	E	Weight
RSVP-UC	0.63	3/4	4.72	9.47	11.75	6.00	7.78	47 lb
		1, 1-1/2	3.25	8.00	11.75	6.00	7.78	47 lb
RSVP-UF	1.00	1-1/2, 2	4.29	10.38	22.38	7.48	9.88	76 lb
		2-1/2	4.29	10.38	22.38	7.48	9.88	76 lb

Dimensions (mm)

Model	Bore	SW (DN)	A	B	C	D	E	Weight
RSVP-UC	16	20	120	241	298	152	198	21 Kg
		25, 40	83	203	298	152	198	21 Kg
RSVP-UF	25	40, 50	109	264	568	190	251	34 Kg
		65	109	264	568	190	251	34 Kg

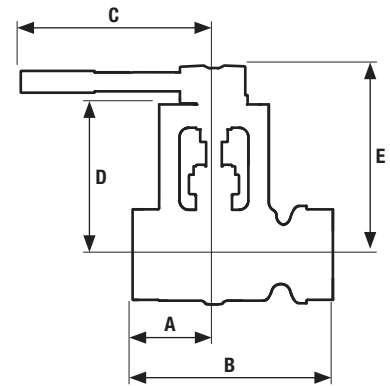

Cv

Bore (inches)	Pipe Size (inches) / Schedule							
	1 Sch 160	1 Sch XXS	1-1/2 Sch 160	1-1/2 Sch XXS	2 Sch 160	2 Sch XXS	2-1/2 Sch 160	2-1/2 Sch XXS
0.63	21	25	12	14	12	13	—	—
1.00	—	—	—	—	38	43	33	37

Temperature vs Pressure — Limited Class Ratings

Class	Mat'l.	Temperature (°F)																	
		-20 to 100	200	300	400	500	600	650	700	750	800	850	900	950	1000	1050	1100		
ASME 4500 Maximum Pressure (psig)	F22²	11250	11250	10090	10915	10865	10815	10735	10605	10605	10605	10160	9000	7556	6213	4064	2546		
	F91	11250	11250	11250	11250	11250	11250	11250	10995	10930	10800	10160	9000	7556	7556	7556	7006		
Class	Mat'l.	Temperature (°C)																	
		-29 to 38	50	100	150	200	250	300	325	350	375	400	425	450	475	500	538	550	575
ASME 4500 Maximum Pressure (barg)	F22²	775	775	774	764	753	750	747	744	738	731	731	708	641	572	428	363	245	160
	F91	775	775	775	775	775	775	775	775	771	757	753	744	756	641	572	539	539	531

²F22 not recommended for prolonged use above 1100°F / 593°C per ASME B16.34.



This ASME 4500 Class RSVP convection vent valve was designed to handle extremely high pressure and elevated temperatures coming from the boiler.