

Applications

Cold Reheat Drains
850°F / 454°C or Below

End Connections

Socketweld

Size

2 inch

Features

ASME TDP-1 1998

- Built for the prevention of water induction into steam turbines in Cold Reheat applications
- Meets and exceeds full, 2-inch bore reliability requirements

Two-Piece, Cast Body

- Available in materials WCC, WC9 and C12A
- Allows for valve repairability

Seat Spring

- Assisted by line pressure, provides a constant mechanical force on ball against seat to maintain seal

Ball & Seats

- Mate-lapped for 100% sealing contact
- Ensures absolute shutoff
- Corrosion resistant
- Seats are protected from flow in open / closed position
- Seats are field replaceable

Inner Stem Seals

- Provides a reliable combination of bearing and pressurized stem seal

Quarter-turn, Non-rising Stem

- Live loading
- Quick open / close operation
- Extends the packing life

Bill of Materials

Item No.	Description	Material
1	Ball	410SS / CC Coated
2	Seat	410SS / CC Coated
3	Spring	Inconel 718
4	Body	WCC, WC9, C12A
5	End Connection	WCC, WC9, C12A
6	Gasket	Spiral Wound
7	Stem	A638 GR660
8	Stem Seal Bearing	410SS / CC Coated Stellite #3
9	Gland Flange	316SS / Moly Coated
10	Stem Packing	Expanded Graphite
11	Anti-Extrusion Ring	Braided Graphite w/ Inconel Wires
12	Pusher Seat	410SS / CC Coated

- Available for Quick Delivery

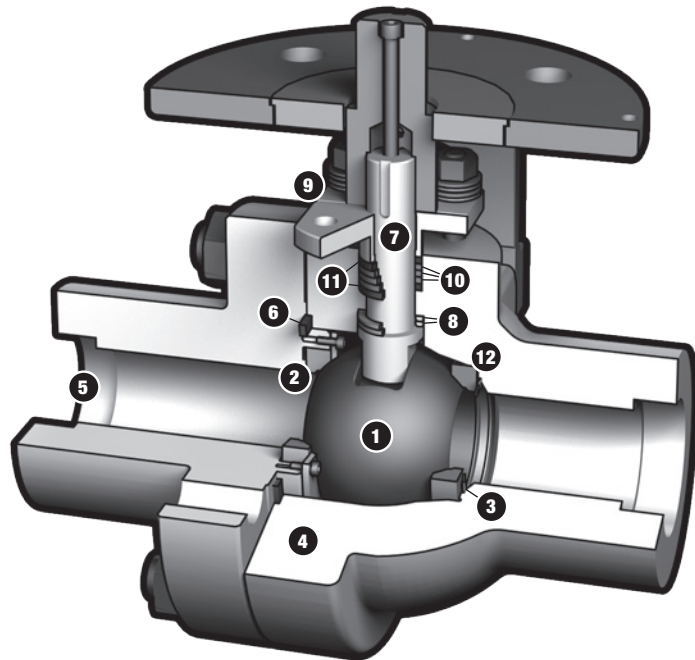

Full Bore Valve Designed to Meet ASME TDP-1 1998

Dimensions (in)

Valve Size	Bore	Class	A	B	C	D	Weight
2	2.00	150 – 600	5.19	11.50	6.23	7.74	82 lb
2	1.87	900 – 1500	5.10	11.50	6.23	7.74	80 lb

Dimensions (mm)

DN	Bore	Class	A	B	C	D	Weight
50	50	150 – 600	132	292	158	197	37 Kg
50	48	900 – 1500	130	292	158	197	36 Kg

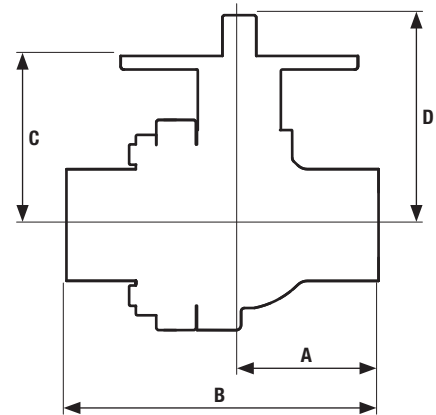

Cv

Bore (inches)	Class	Pipe Size (inches) / Schedule							
		2 Sch 40	2 Sch 80	2 Sch 160	3 Sch 40	3 Sch 80	3 Sch 160	4 Sch 40	
2.00	150 – 600	371	377	332	167	163	—	137	
1.87	900 – 1500	264	317	282	—	145	163	—	

Temperature vs Pressure — Limited Class Ratings

Class	Mat'l.	Temperature (°F)																		
		-20 to 100	200	300	400	500	600	650	700	750	800	850	900	950	1000	1050	1100			
ASME 600 Maximum Pressure (psig)	WCC	1500	1500	1500	1500	1500	1500	1500	1425	1270	1030	N/A ¹	N/A ¹	N/A ¹	N/A ¹	N/A ¹	N/A ¹			
	WC9	1500	1500	1480	1455	1450	1440	1430	1415	1415	1415	1355	1200	953	688	446	282			
	C12A	1500	1500	1500	1500	1500	1500	1500	1465	1460	1440	1355	1200	953	862	862	775			
ASME 900 Maximum Pressure (psig)	WCC	2250	2250	2250	2250	2250	2250	2250	2140	1905	1545	N/A ¹	N/A ¹	N/A ¹	N/A ¹	N/A ¹	N/A ¹			
	WC9	2250	2250	2250	2185	2175	2165	2145	2120	2120	2120	2030	1800	1433	1045	681	426			
	C12A	2250	2250	2250	2250	2250	2250	2250	2200	2185	2160	2030	1800	1433	1311	1311	1175			
ASME 1500 Maximum Pressure (psig)	WCC	3750	3750	3750	3750	3750	3750	3750	3565	3170	2570	N/A ¹	N/A ¹	N/A ¹	N/A ¹	N/A ¹	N/A ¹			
	WC9	3750	3750	3695	3640	3620	3605	3580	3535	3535	3535	3385	3000	2412	1785	1170	732			
	C12A	3750	3750	3750	3750	3750	3750	3750	3665	3645	3600	3385	3000	2412	2250	2250	2015			
Class	Mat'l.	Temperature (°C)																		
		-29 to 38	50	100	150	200	250	300	325	350	375	400	425	450	475	500	538	550	575	600
ASME 600 Maximum Pressure (barg)	WCC	103	103	103	103	103	103	103	103	102	97	87	72	N/A ¹	N/A ¹	N/A ¹	N/A ¹	N/A ¹	N/A ¹	N/A ¹
	WC9	103	103	103	102	100	100	100	99	98	98	98	98	94	86	72	47	40	27	18
	C12A	103	103	103	103	103	103	103	103	103	101	101	99	95	86	72	59	59	59	50
ASME 900 Maximum Pressure (barg)	WCC	155	155	155	155	155	155	155	155	153	145	130	108	N/A ¹	N/A ¹	N/A ¹	N/A ¹	N/A ¹	N/A ¹	N/A ¹
	WC9	155	155	155	153	151	150	149	149	148	146	146	146	141	128	109	72	61	41	27
	C12A	155	155	155	155	155	155	155	155	154	152	151	149	143	128	109	90	90	89	76
ASME 1500 Maximum Pressure (barg)	WCC	259	259	259	259	259	259	259	259	256	242	217	180	N/A ¹	N/A ¹	N/A ¹	N/A ¹	N/A ¹	N/A ¹	N/A ¹
	WC9	259	259	258	255	251	250	249	248	246	244	244	244	236	214	183	123	104	70	46
	C12A	259	259	259	259	259	259	259	259	257	253	251	248	241	214	183	155	155	153	130

¹ WCC not recommended for prolonged use above 800°F / 427°C per ASME B16.34.